

## Cast Iron Mud Valves

Certified to NSF-61 and NSF-372 in USA and Canada

Trumbull Mud Valves are designed primarily for use in settling tanks of water and wastewater treatment plants. Their intended use is to drain tanks for maintenance or cleaning. They are for low pressure applications only; consult Trumbull for special requirements.

Mud Valves are furnished with a 2" square operating nut; however, they can be supplied with optional extension stem or handwheel (see page G-5).

This valve series uses bronze seats in the body and gate (also available with resilient seat). The cast iron body assembly features manganese bronze stems and guides for use in submerged installations. The fasteners are furnished in stainless steel to prevent corrosion from years of submerged service.

Nuts, bolts and gaskets for mounting to floor pipe are NOT furnished but can be ordered separately. Ductile iron components are coated with Tnemec N140-1211 epoxy, per NSF 61.

See pages G-28 and G-29 for drawings.

**i** The flange drilling is according to ANSI 125# STD. on all sizes; however, one hole under each leg of the yoke is not available for fastening to the mating flange.

Size	Non-Rising Stem		Rising Stem	
	Item No	Weight	Item No	Weight
3"	367-1414	26.00 lbs.	367-1421	25.00 lbs.
4"	367-1415	31.00 lbs.	367-1420	30.00 lbs.
6"	367-1416	47.00 lbs.	367-1423	46.00 lbs.
8"	367-1418	76.00 lbs.	367-1425	73.00 lbs.
10"	367-1428	95.00 lbs.	367-1494	90.00 lbs.
12"	367-1430	130.00 lbs.	367-1495	130.00 lbs.
14"	367-1431	142.00 lbs.	Consult Trumbull for availability.	
16"	367-1432	169.00 lbs.		
18"	367-1433	256.00 lbs.		
20"	367-1434	281.00 lbs.		
24"	367-1435	450.00 lbs.		

See page G-34 for installation options.

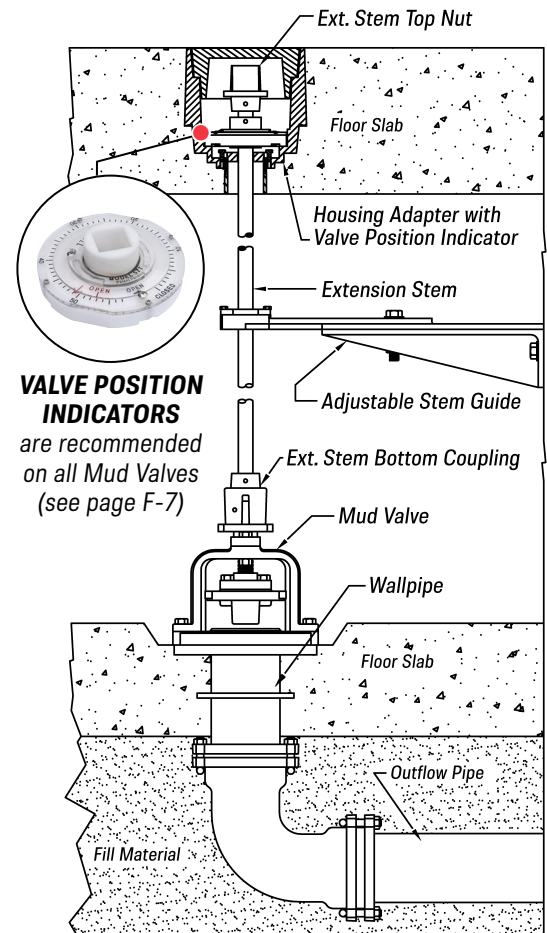
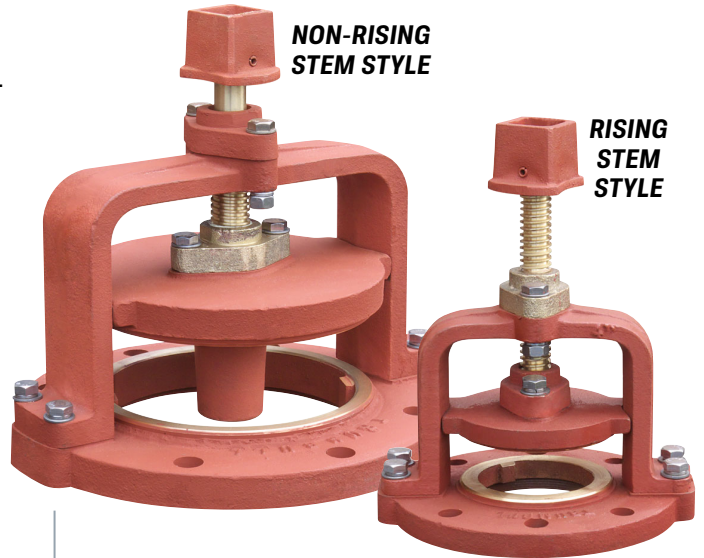

Typical Mud Valve Installation

Valve Size (Bore Dia.)	3	4	6	8	10	12	14	16	18	20	24
A - Overall height	9-7/8	9-1/2	11-1/4	11-3/4	12-13/16	13	15	16-3/4	18-3/4	19-3/4	23-1/2
B - Width at Yoke	10	10	12-3/8	14-1/2	17	19-3/4	22-3/4	24-5/8	28-1/2	30-5/8	37
C - Valve opening	2-1/4	2	3-1/2	4	4-1/16	5	6-3/4	7-3/4	8-1/2	9-3/4	12-1/4
D - Basin depth in floor, min.	1-3/8	1-3/8	1-5/8	1-5/8	1-5/8	1-3/4	1-3/4	1-7/8	2-1/8	2-1/4	2-5/8
E - Flange Thickness	3/4	13/16	1	7/8	7/8	1	1-1/8	1-1/4	1-3/8	1-9/16	1-7/8
Flange O.D.	7-1/2	9	11	13-1/2	16	19	21	23-1/2	25	27-1/2	32
Bolt Circle	6.0	7.5	9.5	11.75	14.25	17.0	18.75	21.25	22.75	25.0	29.5
Bolt Hole Dia.	3/4	3/4	7/8	7/8	1	1	1-1/8	1-1/8	1-1/4	1-1/4	1-3/8
Bolt Dia.	5/8	5/8	3/4	3/4	7/8	7/8	1	1	1-1/8	1-1/8	1-1/4
Bolts in full Pattern* (except 3")	4	8*	8*	8*	12*	12*	12*	16*	16*	20*	20*
Stem Diameter	1	1	1-1/8	1-1/4	1-3/8	1-1/2	1-1/2	1-1/2	1-3/4	1-3/4	1-3/4
Turns to Open	10-1/2	11	17	20	21	25-1/2	34	40	43	49	63
Weight, pounds	26.3	27	47	73	110	130	139	167	243	280	453

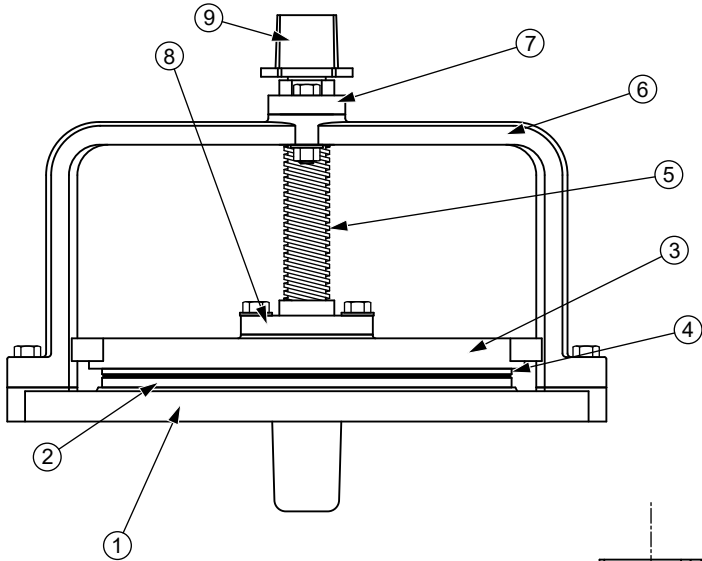

Item	Part	Materials
1	Base Flange (Body)	Gray Iron, ASTM A126 (B)
2	Seat, Base Flange	Bronze, ASTM B62; B584
3	Gate	Ductile Iron, ASTM A536 (65-45-12)
4	Seat, Gate	Bronze, ASTM B62; B584
5	Stem	Bronze, ASTM B584
6	Yoke	Ductile Iron, ASTM A536 (65-45-12)
7	Guide, unthreaded	Ductile Iron, ASTM A536 (65-45-12)
8	Guide, threaded	Bronze, ASTM B584
9	Operating Nut, 2" sq.	Gray Iron, ASTM A126 (B)

All Fasteners are Stainless Steel

Standard 125 pound drilling template.

\* Two of the bolts in the bolt pattern are under the yoke feet and not used (except for 3").

All cast iron surfaces, except machined surfaces, to be finished with NSF61 (TNEMEC 140-1211) coating.

Flange mounting gasket and fasteners are not included, and must be ordered separately.

Also available in Cast T316 Stainless Steel.

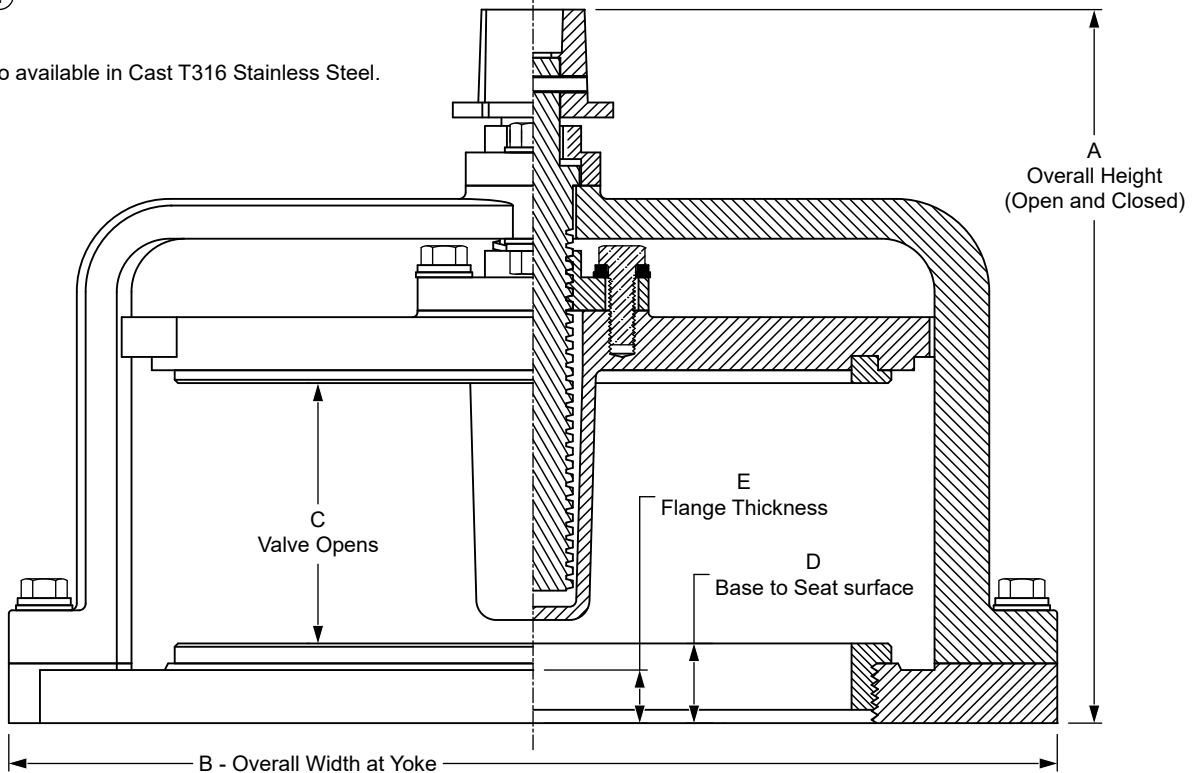

## CAST IRON MUD VALVES NON-RISING STEM TYPE

Drawn to Scale

Drawn:  
FCN  
10/16/17

Revision:  
FCN  
**B** 02/13/20

**Trumbull Manufacturing**  
Youngstown, Ohio  
www.trumbull-mfg.com

Valve Size (Bore Dia.)	3	4	6	8	10	12	14	16**	18**	20**	24**
A - Overall height, closed	9-3/4	9-3/4	11	11-3/4	12-3/4	13	14-1/2	16-3/4	18-3/4	19-3/4	23-1/2
A - Overall height, open	12	11-7/8	14-3/8	15-3/4	16-3/4	18	21-1/2	24-3/4	27-3/4	29-3/4	35-1/2
B - Width at Yoke	10	10	12-3/8	14-1/2	17	19-3/4	22-3/4	24-5/8	28-1/2	30-5/8	37
C - Valve opening	2-1/4	2-1/8	3-3/8	4	4	5	7	8	9	10	12
D - Basin depth in floor, min.	1-3/8	1-3/8	1-5/8	1-5/8	1-5/8	1-3/4	1-3/4	1-7/8	2-1/8	2-1/4	2-5/8
E - Flange Thickness	3/4	13/16	1	7/8	7/8	1	1-1/8	1-1/4	1-3/8	1-9/16	1-7/8
Flange O.D.	7-1/2	9	11	13-1/2	16	19	21	23-1/2	25	27-1/2	32
Bolt Circle	6.0	7.5	9.5	11.75	14.25	17.0	18.75	21.25	22.75	25.0	29.5
Bolt Hole Dia.	3/4	3/4	7/8	7/8	1	1	1-1/8	1-1/8	1-1/4	1-1/4	1-3/8
Bolt Dia.	5/8	5/8	3/4	3/4	7/8	7/8	1	1	1-1/8	1-1/8	1-1/4
Bolts in full Pattern* (except 3")	4	8*	8*	8*	12*	12*	12*	16*	16*	20*	20*
Stem Diameter	1	1	1-1/8	1-1/4	1-3/8	1-1/2	1-1/2	1-1/2	1-3/4	1-3/4	1-3/4
Turns to Open	10-1/2	11	17	20-1/2	20	25	35	40	45	50	60
Weight, pounds	26.3	30	46	73	110	130	140	165	240	280	450

Standard 125 pound drilling template.

\* Two of the bolts in the bolt pattern are under the yoke feet and not used.

All cast iron surfaces, except machined surfaces, to be finished with NSF61 (TNEMEC 140-1211) coating.

Flange mounting gasket and fasteners are not included, and must be ordered separately.

\*\* Consult Trumbull on the availability of 16" and larger sizes in the Rising Stem configuration.

Item	Part	Materials
1	Base Flange (Body)	Gray Iron, ASTM A126 (B)
2	Seat, Base Flange	Bronze, ASTM B62; B584
3	Gate	Ductile Iron, ASTM A536 (65-45-12)
4	Seat, Gate	Bronze, ASTM B62; B584
5	Stem	Bronze, ASTM B584
6	Yoke	Ductile Iron, ASTM A536 (65-45-12)
7	Guide, unthreaded	Ductile Iron, ASTM A536 (65-45-12)
8	Guide, threaded	Bronze, ASTM B584
9	Operating Nut, 2" sq.	Gray Iron, ASTM A126 (B)

All Fasteners are Stainless Steel

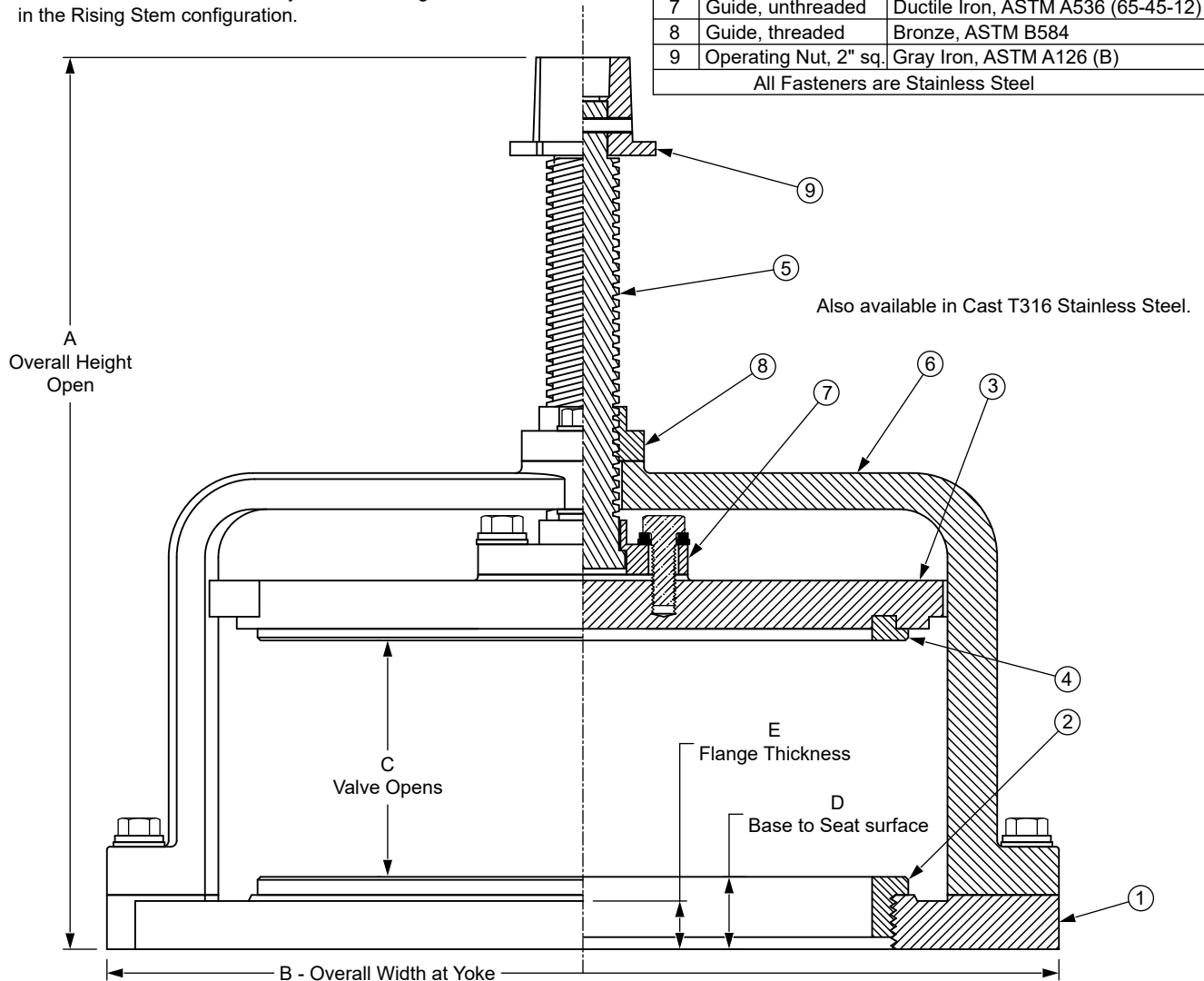

## CAST IRON MUD VALVES RISING STEM TYPE

Drawn to Scale

Drawn:  
FCN  
10/16/17

Revision:  
FCN  
**B** 02/13/20

**Trumbull Manufacturing**  
Youngstown, Ohio  
www.trumbull-mfg.com