

Valve Size (Bore Dia.)	3	4	6	8	10	12	14	16	18	20	24
A - Overall height	9	8	10-1/2	12-1/2	14-1/2	17	23	21-1/4	23	25-3/4	34-5/8
B - Width at Yoke	8	10-1/4	12-5/8	15-1/8	17-3/8	19	25-3/4	25-3/4	27-3/4	27-1/2	32
C - Valve opening	1-1/2	1-3/4	2-3/4	3-1/2	4-3/4	6	7-3/8	7-1/2	8-1/4	9-1/4	12
D - Flange thickness	3/4	3/4	3/4	3/4	3/4	3/4	3/4	3/4	3/4	3/4	3/4
Flange O.D.	7-1/2	9	11	13-1/2	16	19	21.0	23-1/2	25	27-1/2	32
Bolt Circle Diameter	6.00	7.50	9.50	11.75	14.25	17.00	18.75	21.25	22.75	25.00	29.5
Bolt Hole Dia.	3/4	3/4	7/8	7/8	1	1	1-1/8	1-1/8	1-1/4	1-1/4	1-3/8
Bolt / Stud Size	5/8	5/8	3/4	3/4	7/8	7/8	1	1	1-1/8	1-1/8	1-1/4
Bolts in full Pattern*	4	8	8	8	12	12	12	16	16	20	20
Stem Diameter	1-1/4	1-1/4	1-1/4	1-1/2	1-1/2	1-1/2	1-1/2	1-1/2	1-3/4	1-3/4	1-3/4
Turns to Open	7	9	15-1/2	20	26	30	37	20-1/2	23	48-1/2	60
Weight, pounds	19-1/2	24-1/2	33-1/2	48	65	88	125	142	186	206	230

* Standard 125 pound drilling template, with two holes covered by the Yoke (except for 3").

Flange mounting gasket and fasteners are not included, and must be ordered separately.

All items, except for the Seal and the sealing washers are Type 316 Stainless Steel.

Seal and sealing washers are SBR.

All Fasteners are Stainless Steel, Type 316, ASTM A193, Grade B

Stem is coated and greased to prevent galling.

Basin depth in floor for complete draining, 1" minimum.

Part	Description
1	Base Flange (Body)
2	Yoke
3	Gate
4	Seat
5	Seat Retainer
6	Stem
7	Guide, Plain
8	Yoke Cylinder (18"+)
9	Spring Pin
10	2" Square Nut

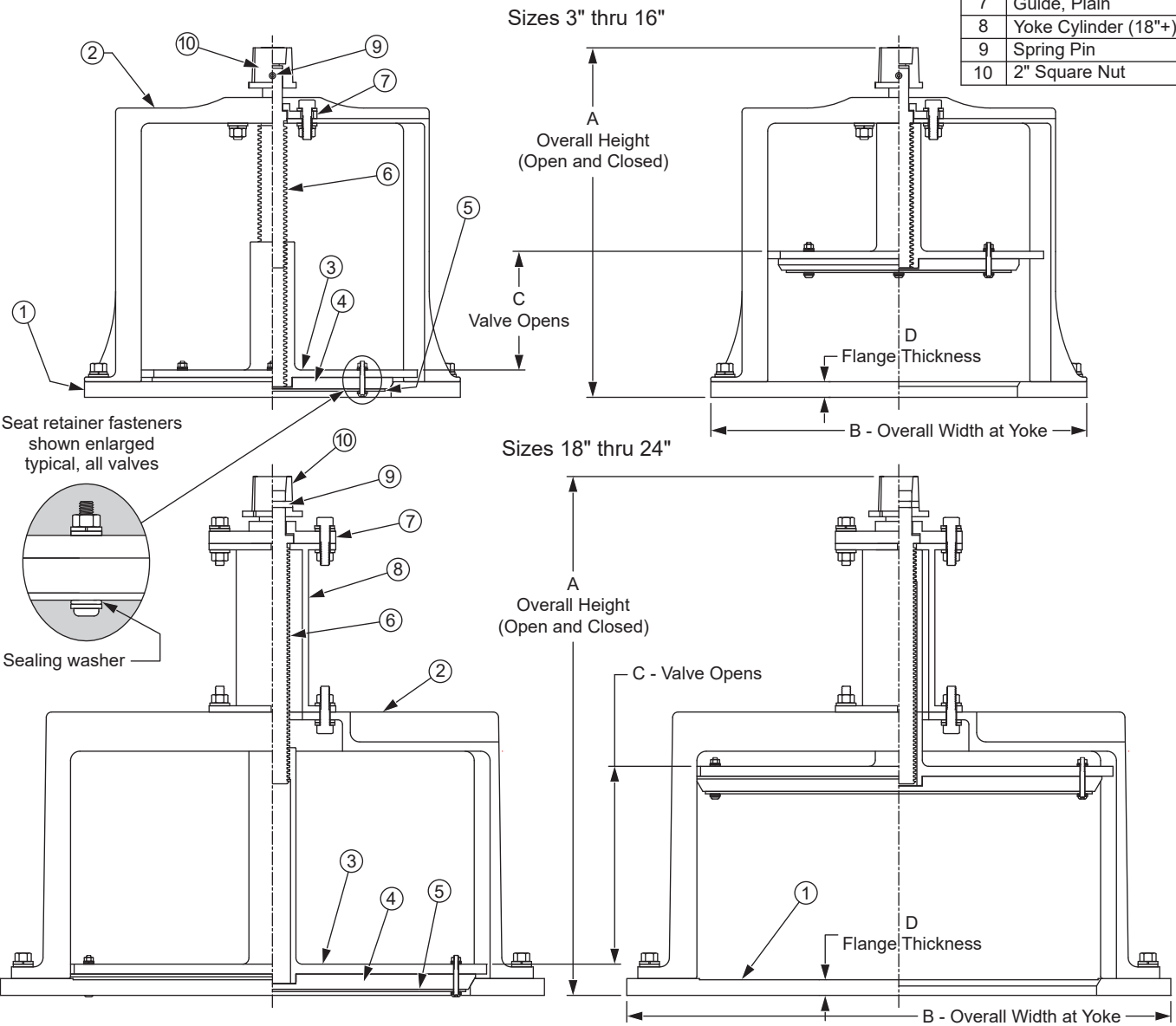

**CAST T316 SS MUD VALVES
NON-RISING STEM TYPE**
Drawn to Scale

Drawn:
FCN
07/24/07

Revision:
FCN
F 02/07/20

Trumbull Manufacturing
Youngstown, Ohio
www.trumbull-mfg.com